



November 2021 Investor Presentation

BRINGING THE FUTURE
FASTER

Forward-Looking Statements



BRINGING THE FUTURE
FASTER

This supplemental information contains forward-looking statements within the meaning of the Private Securities Litigation Reform Act of 1995. These forward-looking statements involve certain risks and uncertainties that could cause actual results to differ materially from those expressed or implied by these statements. These risks and uncertainties include uncertainty around the duration and effects of the COVID-19 pandemic, and include factors detailed in the reports we file with the SEC, including those described under “Risk Factors” in our most recent Annual Report on Form 10-K and our Quarterly Reports on Form 10-Q. These forward-looking statements speak only as of the date of this communication. We expressly disclaim any obligation or undertaking to disseminate any updates or revisions to any forward-looking statement contained herein to reflect any change in our expectations with regard thereto or any change in events, conditions or circumstances on which any such statement is based.

It should also be noted that this information contains certain financial measures, including Adjusted EBITDA, Adjusted Earnings per Share, Adjusted Free Cash Flow, Net Leverage Ratio and Liquidity that are not required by, or presented in accordance with, accounting principles generally accepted in the United States, or GAAP. These measures are presented here to provide additional useful measurements to review our operations, provide transparency to investors and enable period-to-period comparability of financial performance. A description of non-GAAP financial measures that we use to evaluate our operations and financial performance, and reconciliation of these non-GAAP financial measures to the most directly comparable financial measures calculated and reported in accordance with GAAP, can be found in the appendix under “Reconciliation of Non-GAAP Measures”.

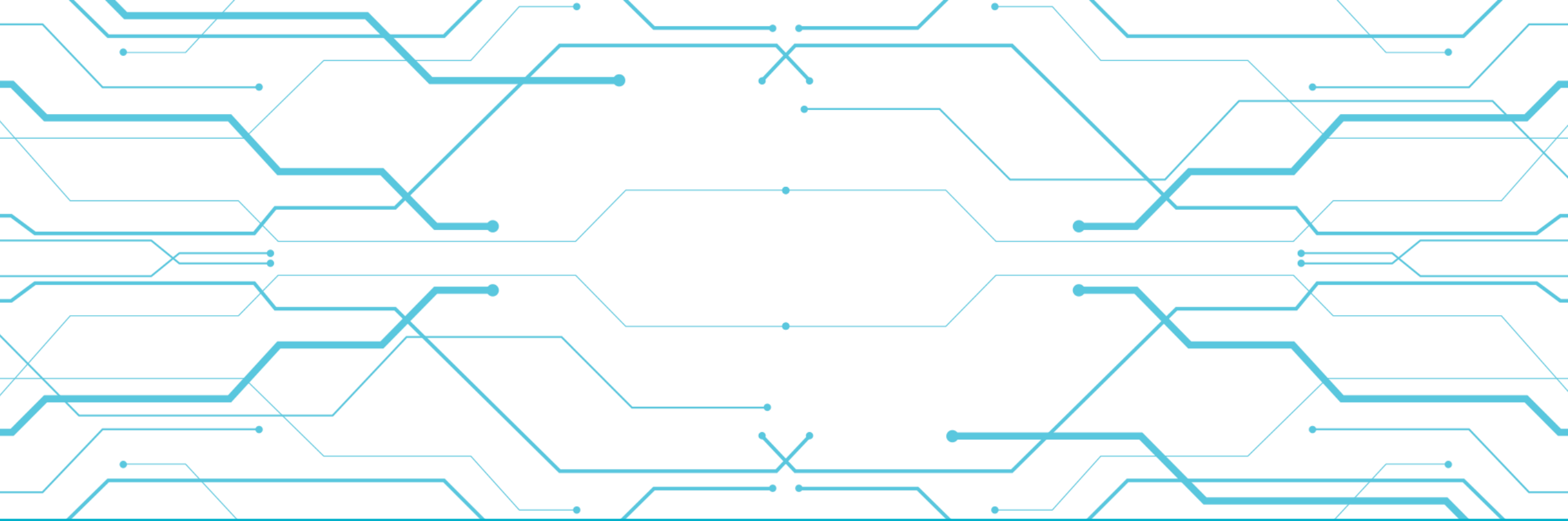

AAM Overview



BRINGING THE FUTURE
FASTER

We Are AAM



BRINGING THE FUTURE
FASTER



2020 SALES

\$4.7B

As a leading, global tier 1 automotive supplier, AAM designs, engineers and manufactures driveline and metal forming technologies that are making the next generation of vehicles smarter, lighter, safer and more efficient

AAM **delivers POWER** that moves the world through world-class quality, technology leadership and operational excellence

Fortune 500

≈20,000
ASSOCIATES



17
COUNTRIES

Nearly
80
LOCATIONS



Over
60
MANUFACTURING
FACILITIES



14
ENGINEERING CENTERS

3Q 2021 AAM Financial Highlights



BRINGING THE FUTURE
FASTER

>\$1.21B

Quarterly
Sales

\$183M

Third Quarter
Adjusted EBITDA

\$69M

Adjusted Free
Cash Flow

AAM Delivers Solid Results Despite Industry Challenges

2021 AAM Highlights



BRINGING THE FUTURE
FASTER



Secured an agreement with REE to supply high-performance electric drive units



Named as the sole-supplier of front and rear pickup axles for GM's Oshawa truck plant



Won Both PACE Partnership and Innovation Awards for Electric Drive Technology



Secured business with NIO supplying differentials for its next generation ePowertrain program



Secured Next Generation Ram Heavy Duty Axle and Driveshaft program

CEO **ACTION** FOR DIVERSITY & INCLUSION

AAM CEO pledges to ACT ON supporting a more inclusive workplace



AAM to supply TracRite Electronic Locking Front Differentials for the new HUMMER EV



Supplying both air and liquid-cooled Power Transfer Units for the all-new Ford Bronco Sport



Continued Strong Free Cash Flow Generation and Debt Reduction

Updated 2021 Financial Outlook (as of November 5, 2021)



BRINGING THE FUTURE
FASTER

2021 Financial Targets

Full Year Sales **\$5.15 to \$5.25 billion**

Adjusted EBITDA **\$830 to \$850 million**

Adjusted Free Cash Flow **~\$400 million**

- Sales range includes approximately \$300 million increase of metal market customer pass-throughs and foreign currency versus last year
- Adjusted Free Cash Flow target assumes capital spending of less than 4.0% of sales
- These targets are based on North American light vehicle production of approximately 13 million units, current customer production and launch schedules and business environment
- AAM expects restructuring and acquisition-related cash payments to be between \$55 and \$65 million



Environment, Social, and Governance



BRINGING THE FUTURE
FASTER

Sustainability Update



BRINGING THE FUTURE
FASTER

In 2021, AAM published a comprehensive sustainability report with the reporting framework based on SASB, GRI, and TCFD standards

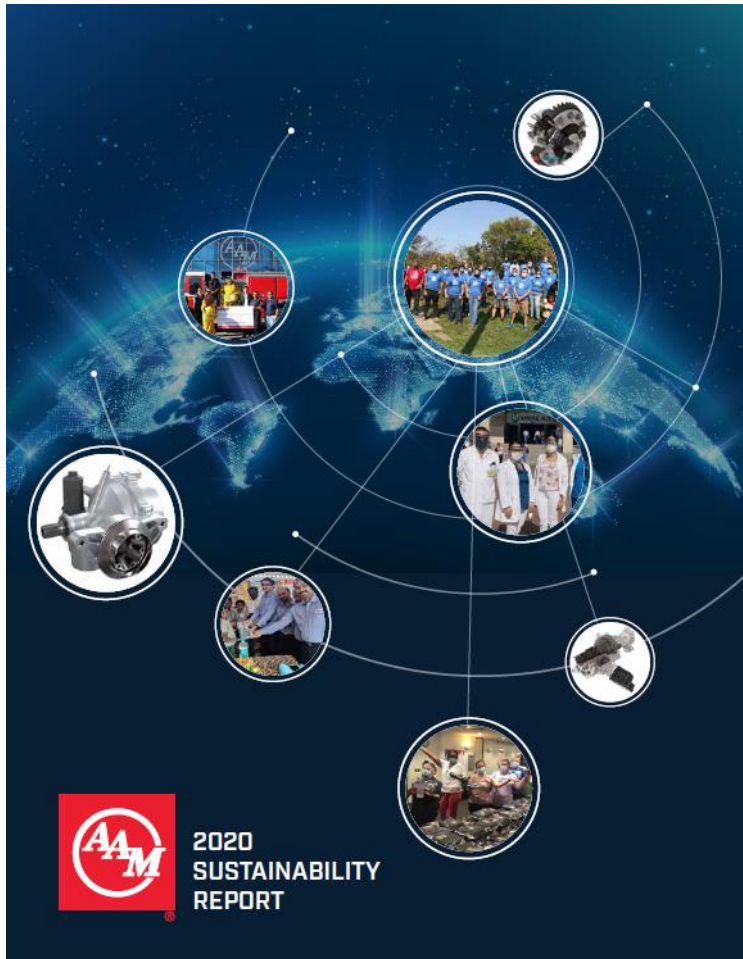

TABLE OF CONTENTS

A Message from our Chairman & CEO	1
We are AAM	2
Sustainability Priority Topics	3
Environmental	4
Our Goals	5
AAM Environmental System E ⁴	7
Environmental Initiatives	8
Carbon Disclosure Project Reporting	13
Social	14
Safety Management System S ⁴	15
Diversity, Equity and Inclusion	17
AAM360	20
#TeamAAM in the Community	26
Governance	28
Sustainability Leadership	29
Ethics and Compliance	30
Supply Chain Compliance	31
Human Rights	33
Industry Associations	33
Product	34
Research and Development	35
Electric Drive Technology	35
AAM Quality System Q ⁴	39
Appendix	
About this Report	A-1
GRI Index	A-3
SASB Index	A-11
TCFD Index	A-12

In a survey conducted by *Institutional Investor*, our Financially Material ESG Disclosures were ranked 1st out of 80+ nominated Small-cap Consumer companies*

*For our 2019 sustainability report

Sustainability: Key Areas of Focus



BRINGING THE FUTURE
FASTER

ENVIRONMENTAL

Energy and Emissions
Reduction

Reduce Water Use
at Every Location

Reduce, Reuse, Recycle
Industrial Materials

SOCIAL

Associate Health, Safety
and Wellness

Attract, Develop, Engage
and Retain Diverse Talent

Partner with
Global Communities

GOVERNANCE

Ethical Business Practices
and Training

Cascade and Verify
Supplier Compliance

PRODUCT

Investment
in Technology

Product Quality
and Safety

Our cross-functional team of subject matter experts considered Global Reporting Initiative (GRI) standards, industry-specific standards of the Sustainability Accounting Standards Board (SASB) and the United Nations Sustainable Development Goals to prioritize sustainability topics and develop performance indicators

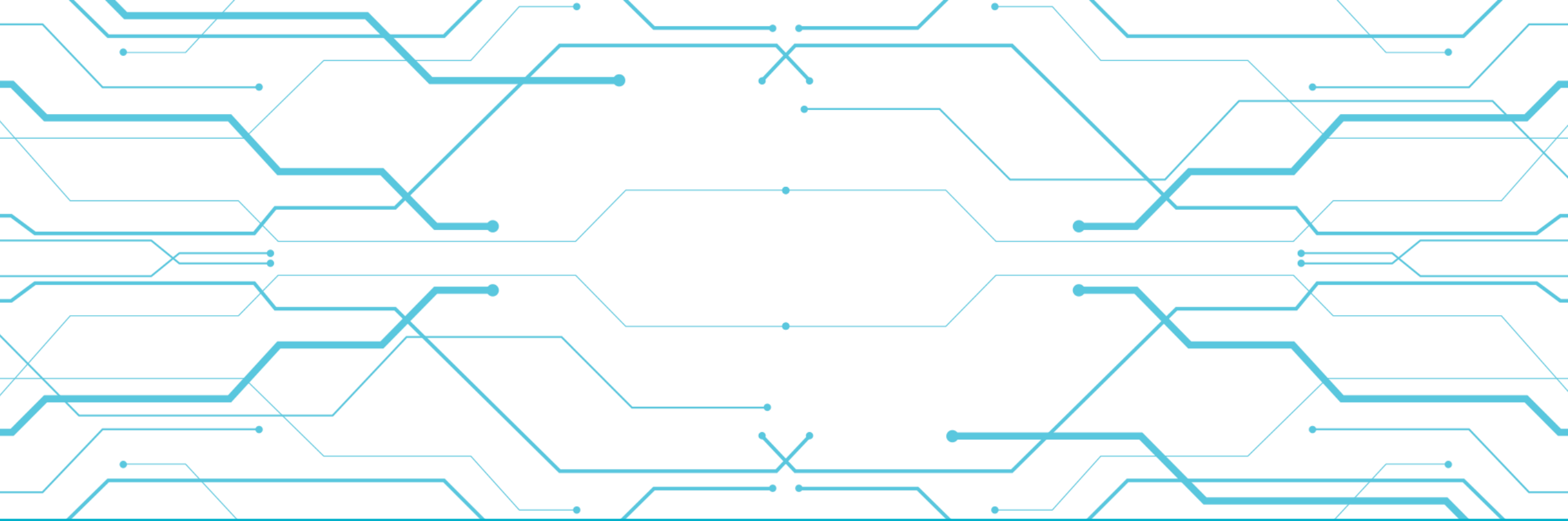

Electrification Product Technology



BRINGING THE FUTURE
FASTER

Significant Content Opportunity



BRINGING THE FUTURE
FASTER

Customer **In-House** Support

Components



Subsystems



Gearboxes

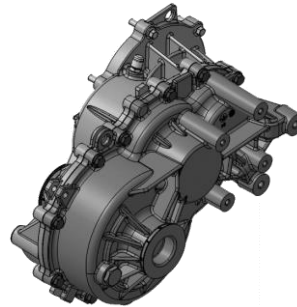

AAM CPV: Up to \$500

Customer **Outsourced** Support

Electric Drive Units

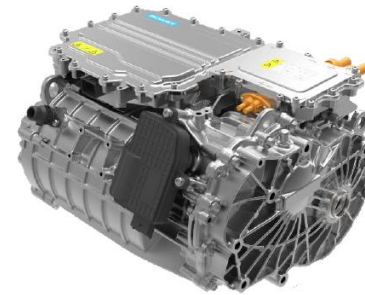

Vehicle Integration & Controls

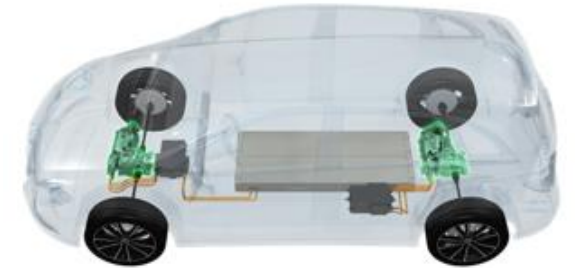

AAM CPV: Up to \$2,500+

AAM is Positioned to Support All OEM Sourcing Strategies

AAM Electrification History

Key Business Awards in Electrification To Date



BRINGING THE FUTURE
FASTER

2-in-1 Electric Drive Units

Jaguar I-PACE (Europe)

- Two P4 Electric Drive Units
- 150 kW Power Level
- Power Dense Concentric Design
- Integrated Park Lock (Front EDU only)



Baojun E300 City Car (China)

- P4 Gearbox
- 40 kW Peak Power
- Offset Gearbox Design
- Integrated Park Lock

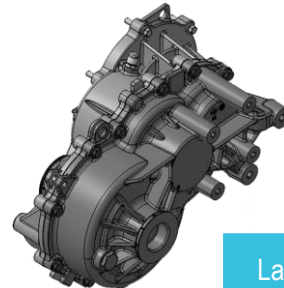

High Performance Luxury OEM (Europe)

- P3 Hybrid Electric Drive Unit
- 160kW Peak Power
- 2-speed Concentric Gearbox Design
- Integrated TracRite® eLSD

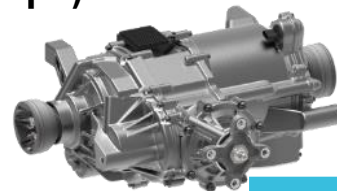

3-in-1 Electric Drive Units (Platform)

AAM / Inovance 3-in-1 eDrive (China)

- P4 Platform Electric Drive Units
- Scalable Power Level based on Application
- Offset Gearbox Design
- Optional Park Lock

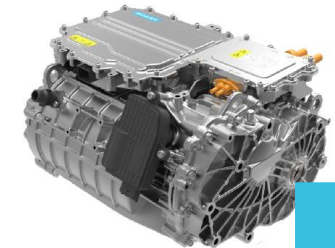

AAM Next Generation 3-in-1 eDrive

- Wheel End eDrive Units
- Compact Offset Gearbox Design
- High power density

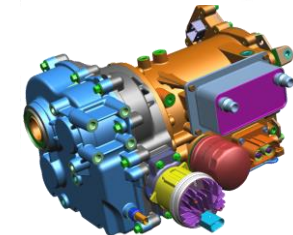

Electric Drive Components

Planetary Geartrain

- European BEV Passenger Car Application



Electric Drive Unit Differentials

- Multiple Chinese BEV Car & SUV Applications
- North American BEV Pick-up Truck Application
- North American BEV Semi-Truck Application



AAM Next Generation Electric Drive



BRINGING THE FUTURE
FASTER

Market Critical Attributes

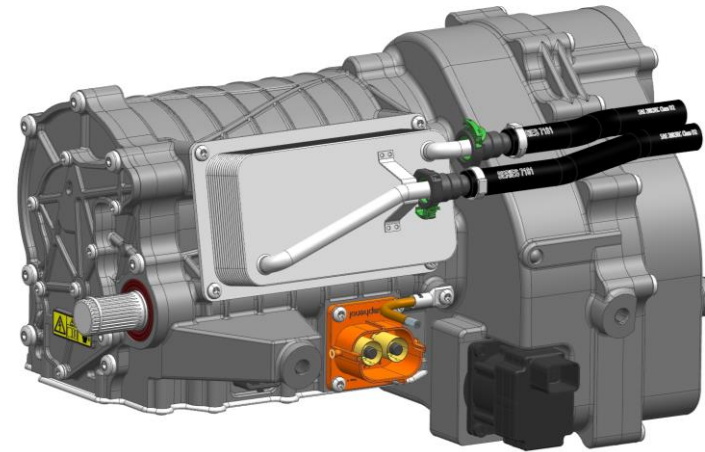
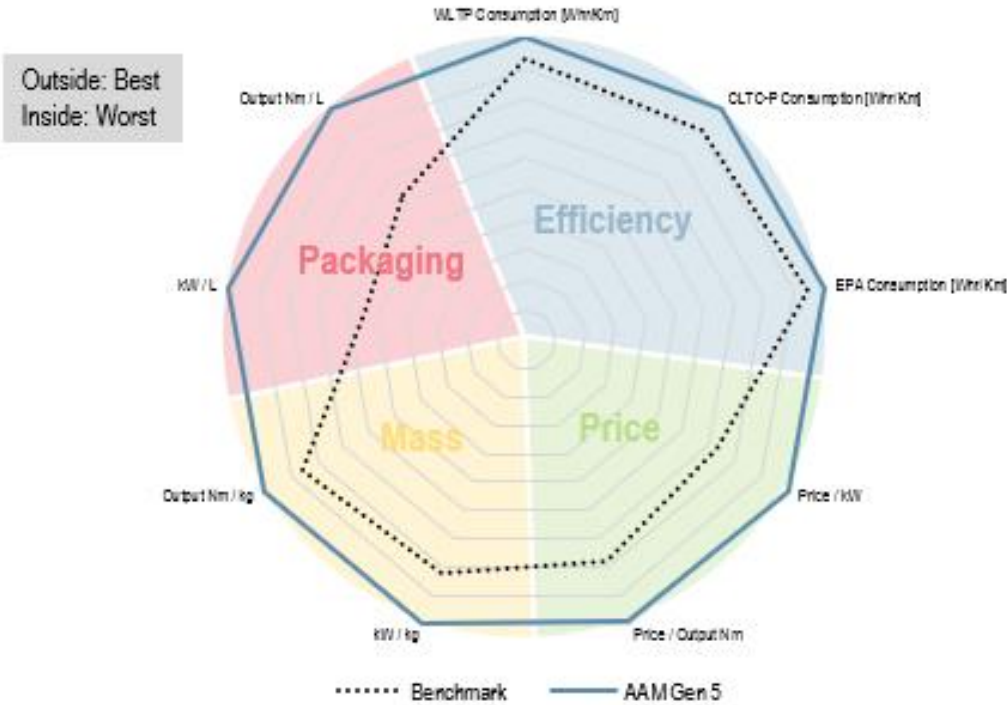

AAM Next Generation Electric Drive Units Deliver Compelling Performance

>10%

Improvement in
Mass Efficiency

>40%

Improvement in
Volumetric
Efficiency

>40%

Improvement in
Power Density

>10%

Reduced Power
Loss, More
Range

Strong Value
Proposition

AAM's Next Generation Electric Drive exceeds widely recognized industry benchmark in terms of critical EDU attributes

Scalable & Modular Platform



BRINGING THE FUTURE
FASTER

AAM's Next Generation Scalable & Modular Electric Drive Units support numerous vehicle applications while optimizing capital and development costs

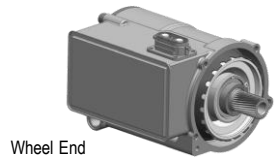

Wheel End

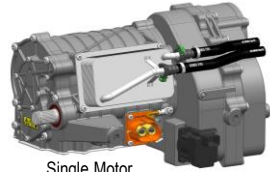

Single Motor

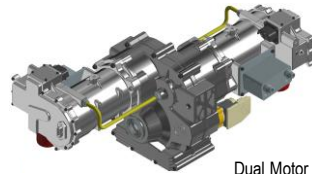

Dual Motor

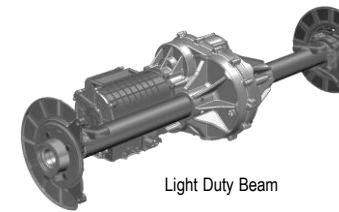

Light Duty Beam

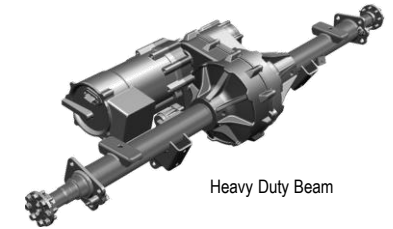

Heavy Duty Beam

Scalable Power Levels

Modular Motor Construction

Various EDU Architectures

Multiple Gear Ratios

Optional Torque
Vectoring & Disconnect



P3 HYBRID ARCHITECTURE

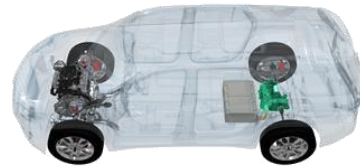

P4 SPLIT AXLE HYBRID ARCHITECTURE



P4 RWD ARCHITECTURE



P4 AWD MPV ARCHITECTURE

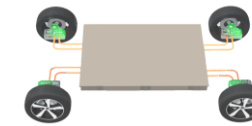

P4 AWD ARCHITECTURE



P4 FWD ARCHITECTURE

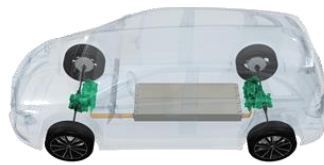

P4 AWD ARCHITECTURE



P4 4WD ARCHITECTURE



P4 4WD HD ARCHITECTURE

 Denotes AAM EDU application

Electrification Summary



BRINGING THE FUTURE
FASTER

Proven electric drive systems design and integration capabilities in production

Well positioned to support all OEM sourcing strategies leveraging our strengths in software, integration, and manufacturing

Global reach and scalable product portfolio to serve all segments and major markets

Strategic partnerships to further accelerate the development and delivery of scalable, next-generation 3-in-1 electric drive systems

Highly integrated product technology resulting in improved power density, value, and efficiency

Next generation electric drive system is positioning us for continued profitable growth

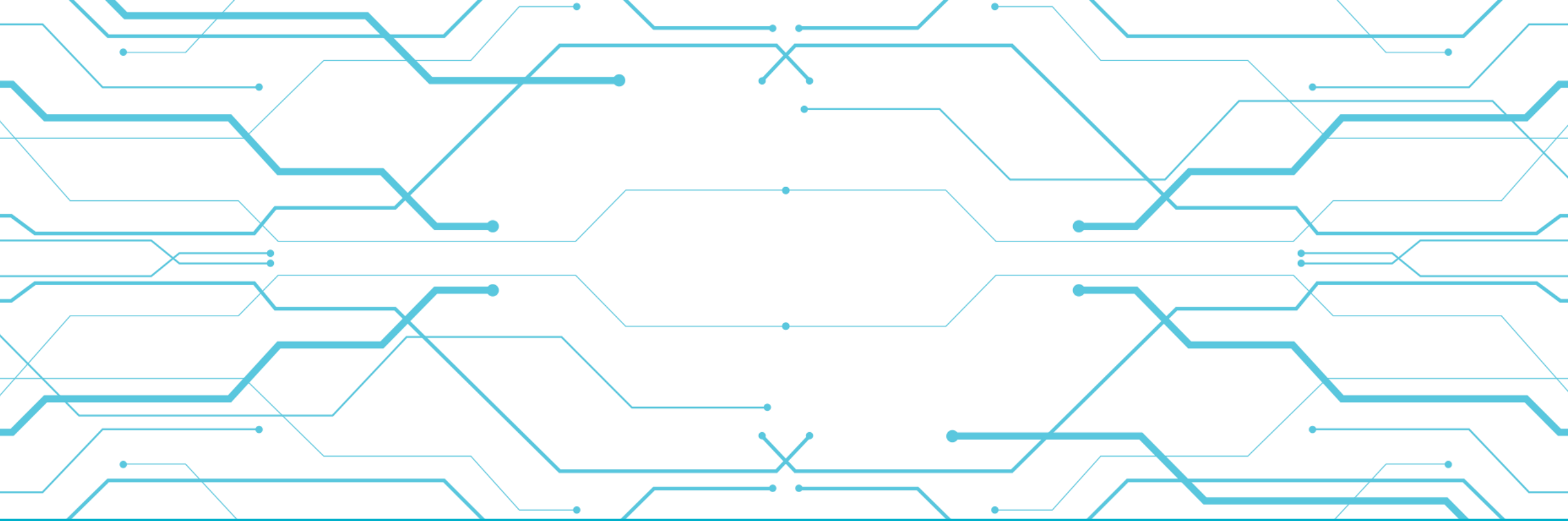

Supplemental Data



BRINGING THE FUTURE
FASTER

Reconciliation of Non-GAAP Measures



BRINGING THE FUTURE
FASTER

In addition to the results reported in accordance with accounting principles generally accepted in the United States of America (GAAP) included within this presentation, we have provided certain information, which includes non-GAAP financial measures. Such information is reconciled to its closest GAAP measure in accordance with Securities and Exchange Commission rules and is included in the following slides.

Certain of the forward-looking financial measures included in this earnings release are provided on a non-GAAP basis. A reconciliation of non-GAAP forward-looking financial measures to the most directly comparable forward-looking financial measures calculated and presented in accordance with GAAP has been provided. The amounts in these reconciliations are based on our current estimates and actual results may differ materially from these forward-looking estimates for many reasons, including potential event driven transactional and other non-core operating items and their related effects in any future period, the magnitude of which may be significant.



EBITDA and Adjusted EBITDA Reconciliation
(\$ in millions)

	Three Months Ended September 30,		Nine Months Ended September 30,	
	2021	2020	2021	2020
Net income (loss)	\$ (2.4)	\$ 117.2	\$ 52.2	\$ (597.2)
Interest expense	49.7	53.9	150.7	160.0
Income tax benefit	(13.6)	(22.5)	(2.4)	(63.1)
Depreciation and amortization	135.6	125.0	421.2	393.7
EBITDA	169.3	273.6	621.7	(106.6)
Restructuring and acquisition-related costs	7.4	9.7	40.8	38.6
Debt refinancing and redemption costs	31.6	5.2	34.0	6.7
Impairment charges	0.0	0.0	0.0	510.0
Unrealized gain on equity securities	(19.4)	0.0	(19.4)	0.0
Loss on sale of business	0.0	0.0	2.7	1.0
Non-recurring items:				
Malvern fire charges, net of recoveries	(5.7)	8.6	(11.1)	8.6
Adjusted EBITDA	\$ 183.2	\$ 297.1	\$ 668.7	\$ 458.3
Sales	1,213.1	1,414.1	3,921.5	3,272.9
as a % of net sales	15.1%	21.0%	17.1%	14.0%

Supplemental Data



BRINGING THE FUTURE
FASTER

EBITDA and Adjusted EBITDA for the Trailing Twelve Months Ended September 30, 2021
(\$ in millions)

	Quarter Ended				Trailing Twelve
	December 31, 2020	March 31, 2021	June 30, 2021	September 30, 2021	Months Ended September 30, 2021
Net income (loss)	\$ 36.1	\$ 38.6	\$ 16.0	\$ (2.4)	\$ 88.3
Interest expense	52.3	51.1	49.9	49.7	203.0
Income tax expense (benefit)	13.9	8.8	2.4	(13.6)	11.5
Depreciation and amortization	128.2	142.0	143.6	135.6	549.4
EBITDA	230.5	240.5	211.9	169.3	852.2
Restructuring and acquisition-related cost	28.6	17.5	15.9	7.4	69.4
Debt refinancing and redemption costs	1.2	1.1	1.3	31.6	35.2
Pension settlement	0.5	-	-	-	0.5
Loss on sale of business	-	2.6	0.1	-	2.7
Unrealized gain on equity securities	-	-	-	(19.4)	(19.4)
Non-recurring items:					
Malvern fire charges, net of recoveries	0.7	1.2	(6.6)	(5.7)	(10.4)
Adjusted EBITDA	\$ 261.5	\$ 262.9	\$ 222.6	\$ 183.2	\$ 930.2
Sales	1,437.9	1,425.1	1,283.3	1,213.1	5,359.4
as a % of net sales	18.2%	18.4%	17.3%	15.1%	17.4%



Adjusted Earnings (Loss) Per Share Reconciliation

	Three Months Ended September 30,		Nine Months Ended September 30,	
	2021	2020	2021	2020
Diluted earnings (loss) per share	\$ (0.02)	\$ 0.99	\$ 0.44	\$ (5.28)
Restructuring and acquisition-related costs	0.06	0.08	0.33	0.34
Debt refinancing and redemption costs	0.27	0.05	0.29	0.06
Loss on sale of business	-	-	0.02	0.01
Impairment charges	-	-	-	4.51
Accelerated depreciation*	0.08	-	0.27	0.14
Unrealized gain on equity securities	(0.16)	-	(0.16)	-
Non-recurring items:				
Malvern fire charges, net of recoveries	(0.05)	0.07	(0.09)	0.08
Tax adjustments related to the CARES Act	-	-	-	(0.07)
Adjustments to liability for unrecognized tax benefits	-	-	-	(0.06)
Tax effect of adjustments	(0.03)	(0.04)	(0.09)	(0.12)
Adjusted earnings (loss) per share	\$ 0.15	\$ 1.15	\$ 1.01	\$ (0.39)

*Please refer to definition of Non-GAAP measures



Free Cash Flow and Adjusted Free Cash Flow Reconciliation (\$ in millions)

	Three Months Ended September 30,		Nine Months Ended September 30,	
	2021	2020	2021	2020
Net cash provided by operating activities	\$ 89.8	\$ 249.5	\$ 436.0	\$ 246.4
Capital expenditures net of proceeds from the sale of property, plant and equipment	(33.2)	(40.5)	(114.0)	(144.7)
Free cash flow	56.6	209.0	322.0	101.7
Cash payments for restructuring and acquisition-related costs	9.0	8.2	47.9	37.0
Cash payments related to the Malvern fire net of recoveries	3.5	-	9.4	-
Adjusted free cash flow	\$ 69.1	\$ 217.2	\$ 379.3	\$ 138.7



Net Debt and Net Leverage Ratio (\$ in millions)

	September 30, 2021
Current portion of long-term debt	\$ 14.6
Long-term debt, net	3,104.1
Total debt, net	3,118.7
Less: cash and cash equivalents	500.7
Net debt at end of period	2,618.0
Adjusted LTM EBITDA	\$ 930.2
Net Leverage Ratio	2.8X



Segment Financial Information
(\$ in millions)

	Three Months Ended		Nine Months Ended	
	September 30,		September 30,	
	2021	2020	2021	2020
Segment Sales				
Driveline	\$ 870.4	\$ 1,025.0	\$ 2,831.9	\$ 2,346.7
Metal Forming	422.7	497.4	1,352.1	1,147.7
Total Sales	1,293.1	1,522.4	4,184.0	3,494.4
Intersegment Sales	(80.0)	(108.3)	(262.5)	(221.5)
Net External Sales	\$ 1,213.1	\$ 1,414.1	\$ 3,921.5	\$ 3,272.9
Segment Adjusted EBITDA				
Driveline	\$ 128.4	\$ 199.5	\$ 450.2	\$ 309.0
Metal Forming	54.8	97.6	218.5	149.3
Total Segment Adjusted EBITDA	\$ 183.2	\$ 297.1	\$ 668.7	\$ 458.3

Supplemental Data



BRINGING THE FUTURE
FASTER

	Adjusted EBITDA	
	Low End	High End
	<i>(in millions)</i>	
Net income	\$ 20	\$ 35
Interest expense	200	200
Income tax benefit	(5)	-
Depreciation and amortization	545	545
Full year 2021 targeted EBITDA	760	780
Restructuring and acquisition-related costs	60	60
Other	10	10
Full year 2021 targeted Adjusted EBITDA	<u>\$ 830</u>	<u>\$ 850</u>

	Adjusted Free Cash Flow	
	<i>(in millions)</i>	
Net cash provided by operating activities	\$	520
Capital expenditures net of proceeds from the sale of property, plant and equipment		(190)
Full year 2021 targeted Free Cash Flow		330
Cash payments for restructuring and acquisition-related costs		60
Other		10
Full year 2021 targeted Adjusted Free Cash Flow	<u>\$</u>	<u>400</u>

Definition of Non-GAAP Measures



BRINGING THE FUTURE
FASTER

EBITDA and Adjusted EBITDA

We define EBITDA to be earnings before interest expense, income taxes, depreciation and amortization. Adjusted EBITDA is defined as EBITDA excluding the impact of restructuring and acquisition-related costs, debt refinancing and redemption costs, loss on sale of a business, impairment charges, pension settlements, unrealized gains or losses on equity securities and non-recurring items. We believe that EBITDA and Adjusted EBITDA are meaningful measures of performance as they are commonly utilized by management and investors to analyze operating performance and entity valuation. Our management, the investment community and the banking institutions routinely use EBITDA and Adjusted EBITDA, together with other measures, to measure our operating performance relative to other Tier 1 automotive suppliers. We also use Segment Adjusted EBITDA as the measure of earnings to assess the performance of each segment and determine the resources to be allocated to the segments. EBITDA and Adjusted EBITDA are also key metrics used in our calculation of incentive compensation. EBITDA and Adjusted EBITDA should not be construed as income from operations, net income or cash flow from operating activities as determined under GAAP. Other companies may calculate EBITDA and Adjusted EBITDA differently.

Adjusted Earnings (Loss) Per Share

We define Adjusted earnings (loss) per share to be diluted earnings per share excluding the impact of restructuring and acquisition-related costs, debt refinancing and redemption costs, loss on sale of a business, impairment charges, pension settlements, certain accelerated depreciation, unrealized gains or losses on equity securities and non-recurring items, including the tax effect thereon. We believe Adjusted earnings (loss) per share is a meaningful measure as it is commonly utilized by management and investors in assessing ongoing financial performance that provides improved comparability between periods through the exclusion of certain items that management believes are not indicative of core operating performance and which may obscure underlying business results and trends. Other companies may calculate Adjusted earnings (loss) per share differently.

Free Cash Flow and Adjusted Free Cash Flow

We define free cash flow to be net cash provided by operating activities less capital expenditures net of proceeds from the sale of property, plant and equipment. Adjusted free cash flow is defined as free cash flow excluding the impact of cash payments for restructuring and acquisition-related costs and cash payments related to the Malvern fire, including payments for capital expenditures, net of recoveries. We believe free cash flow and Adjusted free cash flow are meaningful measures as they are commonly utilized by management and investors to assess our ability to generate cash flow from business operations to repay debt and return capital to our stockholders. Free cash flow and Adjusted free cash flow are also key metrics used in our calculation of incentive compensation. Other companies may calculate free cash flow and Adjusted free cash flow differently.

Net Debt and Net Leverage Ratio

We define net debt to be total debt, net less cash and cash equivalents. We define Net Leverage Ratio to be net debt divided by the trailing 12 months of Adjusted EBITDA. We believe that Net Leverage Ratio is a meaningful measure of financial condition as it is commonly used by management, investors and creditors to assess capital structure risk. Other companies may calculate Net Leverage Ratio differently.

Liquidity

We define Liquidity as cash on hand plus amounts available on our revolving credit facility and foreign credit facilities.

US SAAR

We define US SAAR as the seasonally adjusted annual rate of light vehicle sales in the United States.

Accelerated Depreciation

In the first quarter of 2021, one of our largest customers announced their intention to cease production operations in Brazil in 2021 as part of their restructuring actions. As such, we have accelerated depreciation on certain property, plant and equipment beginning in the first quarter of 2021. In the first six months of 2020, we accelerated depreciation for certain assets that were idled as a result of our largest customer exiting their operations in Thailand, which they announced in the first quarter of 2020.

