



# June 2023 Investor Presentation

BRINGING THE FUTURE  
FASTER

# Forward-Looking Statements



BRINGING THE FUTURE  
FASTER

This presentation information contains forward-looking statements within the meaning of the Private Securities Litigation Reform Act of 1995. These forward-looking statements involve certain risks and uncertainties that could cause actual results to differ materially from those expressed or implied by these statements. These risks and uncertainties include factors detailed in the reports we file with the SEC, including those described under “Risk Factors” in our most recent Annual Report on Form 10-K and our Quarterly Reports on Form 10-Q. These forward-looking statements speak only as of the date of this communication. We expressly disclaim any obligation or undertaking to disseminate any updates or revisions to any forward-looking statement contained herein to reflect any change in our expectations with regard thereto or any change in events, conditions or circumstances on which any such statement is based.

It should also be noted that this information contains certain financial measures, including Adjusted EBITDA, Adjusted Earnings per Share, Adjusted Free Cash Flow, Net Leverage Ratio and Liquidity that are not required by, or presented in accordance with, accounting principles generally accepted in the United States, or GAAP. These measures are presented here to provide additional useful measurements to review our operations, provide transparency to investors and enable period-to-period comparability of financial performance. A description of non-GAAP financial measures that we use to evaluate our operations and financial performance, and reconciliation of these non-GAAP financial measures to the most directly comparable financial measures calculated and reported in accordance with GAAP, can be found in the appendix under “Reconciliation of Non-GAAP Measures.”

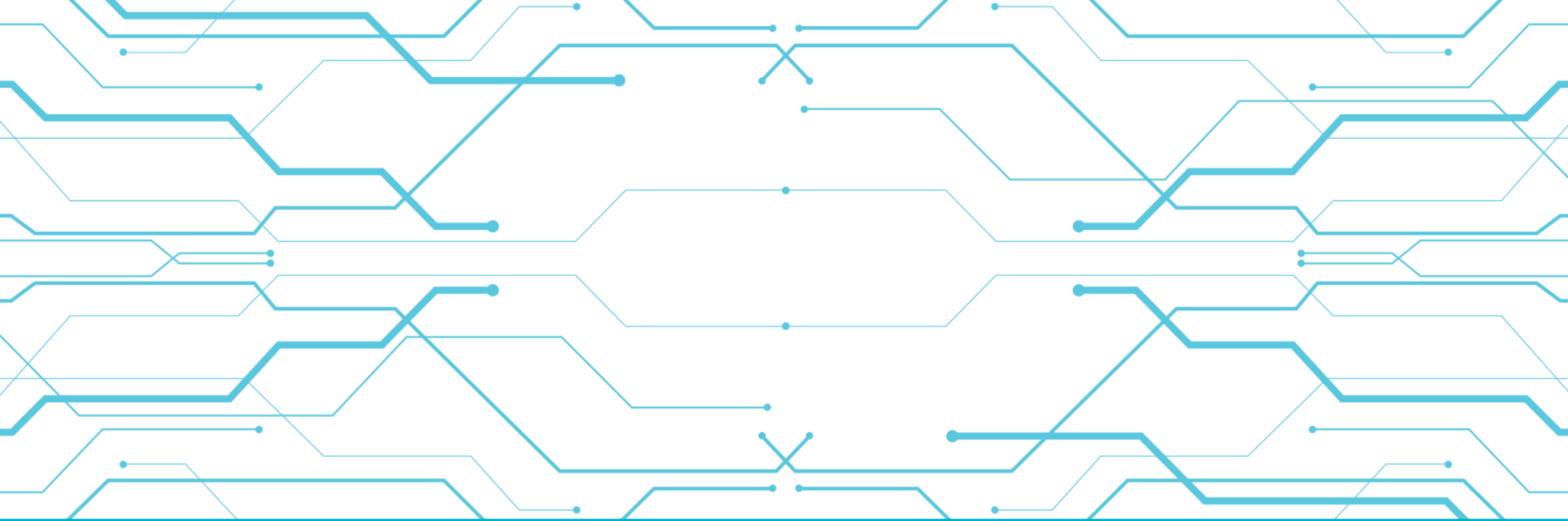

# AAM Overview



BRINGING THE FUTURE  
FASTER

**Global-leader in design, engineering and manufacturing of automotive propulsion systems and technologies to support electric, hybrid and ICE vehicles**



**\$5.8B 2022 Revenue**



**~19,000 Employees**



**18 Countries**



**Over 80 Locations**



**14 Global Engineering and Tech Centers**

## DRIVELINE



- One of the leaders in hybrid and electric driveline solutions
- A Global Leader in
  - Full-size Pickup Truck and SUV Driveline Systems
  - AWD Systems for Crossover Vehicles
  - Damped Gears, Viscous Dampers and Rubber Isolation Pulleys
- Pioneer of Disconnecting AWD Systems

## METAL FORMING

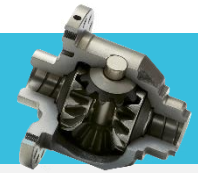

- Strong position in electrified propulsion components
- Leading automotive forger in the world
- A Global Leader in
  - Forged Gears & Shafts
  - CVT Pulleys
  - Powdered Metal Connecting Rods
  - Aluminum Valve Bodies
  - Machined Helical Gears
  - Differential Assemblies

# 2022 AAM Highlights



BRINGING THE FUTURE  
**FASTER**



AAM electric drive unit powers Mercedes-AMG GT 63 S E PERFORMANCE



Announced contracts valued at more than \$10 billion for next-gen full-size truck axle programs with multiple customers



Recognized as an Overdrive Award winner at General Motors' 30th annual Supplier of the Year awards



Awarded multiple contracts to supply major global OEMs with electric components for electric drive units



AAM is the new axle supplier for GM's next generation Colorado and Canyon (debut in model year 2023)



Named to Forbes' list of America's Best Large Employers



AAM Recognized with Three PACE Awards for Innovative EV Technology



Acquisition of Tekfor to provide synergies, diversify sales mix and increase electrification product portfolio



2021 Sustainability Report expanded commitment to net zero emissions by 2040

# 1Q 2023 AAM Financial Highlights



BRINGING THE FUTURE  
FASTER

**\$1.49B**

Quarterly  
Sales

**\$175.4M**

First Quarter  
Adjusted EBITDA

**\$(17.1)M**

Adjusted Free  
Cash Flow

**AAM Delivered in a Volatile Operating Environment**

# Business Update



BRINGING THE FUTURE  
FASTER



## Stellantis e-Beam Axle

AAM to supply e-Beam axles for a future electric vehicle program. The future program is expected to begin production in the latter part of the decade and will feature both front and rear e-Beam axles which includes AAM's integrated 3-in-1 e-Drive technology.

## EnerTech Capital

AAM announced an investment in the Global Strategic Mobility Fund, a venture capital fund managed by EnerTech Capital. The investment provides AAM with access to new startup and fully vetted high-tech companies that are advancing automotive technologies.

## GM Overdrive Award

GM recognized AAM as an Overdrive award winner for sustainability as part of GM's 31st annual Supplier of the Year awards. Each year, award recipients are selected by a global, cross-functional GM team for their performance in multiple criteria.

## Forbes Award

AAM is once again on Forbes list of America's Best Large Employers. This prestigious award is presented by Forbes and Statista Inc. This is AAM's fourth selection, having appeared on the list in 2022, 2018 and 2017.

# Gross New Business Backlog (disclosed on January 4, 2023)



BRINGING THE FUTURE  
FASTER

## \$725 Million Backlog (2023-2025)

### Backlog By Segment

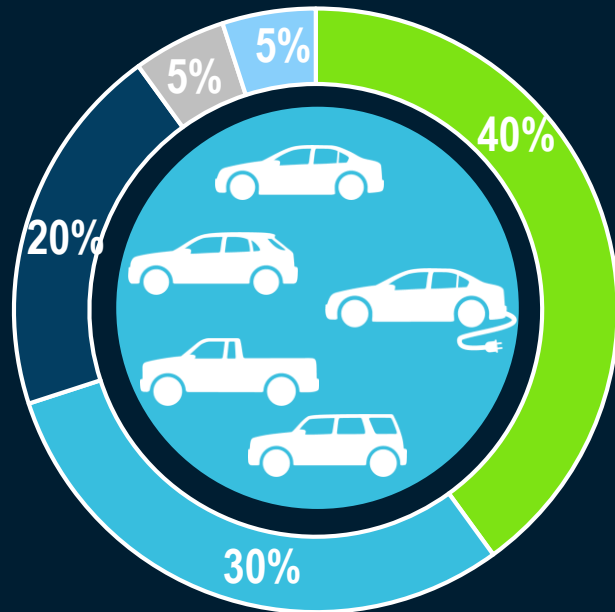

■ Electric ■ Trucks/SUV ■ Crossover ■ Pass Car ■ Other

### Backlog By Geography

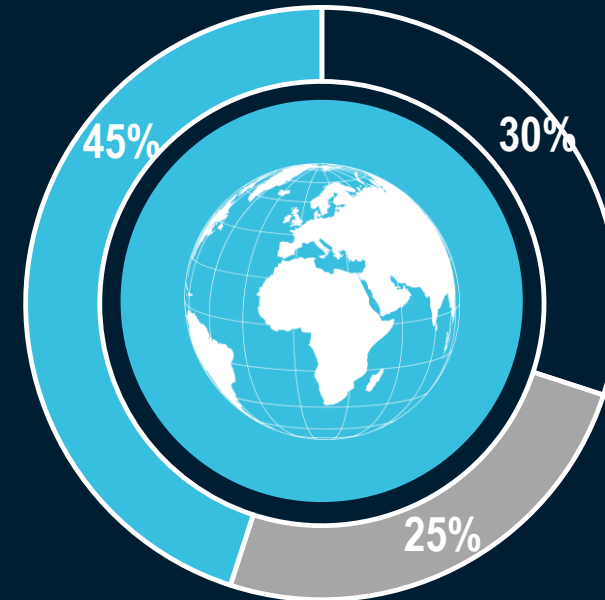

■ Asia ■ Europe ■ Americas

Electrification continues to be a growing portion of AAM's new business backlog





## 2023 Financial Targets

|                                |                                 |
|--------------------------------|---------------------------------|
| <b>Full Year Sales</b>         | <b>\$5.95 to \$6.25 billion</b> |
| <b>Adjusted EBITDA</b>         | <b>\$725 to \$800 million</b>   |
| <b>Adjusted Free Cash Flow</b> | <b>\$225 to \$300 million</b>   |

- These targets are based on North American light vehicle production range of 14.5 – 15.1 million units, current customer production and launch schedules and business environment
- Adjusted Free Cash Flow target assumes capital spending in the range of 3.5% - 4.0% of sales
- AAM expects restructuring and acquisition-related cash payments to be between \$20 and \$30 million

# 2022 Sustainability Report



BRINGING THE FUTURE  
FASTER

## Report Highlights

- New sustainability report was published in April 2023
- Achieved an A- on the CDP Climate Change survey
- Achieved Silver Status on the EcoVadis Sustainability Assessment
- Achieved SBTi validation of GHG Emissions goals
- Named one of America's Best Large Employers by Forbes
- Improved on all Safety Performance metrics
- Completed a sustainability materiality assessment
- Launched 17 major global product programs
- Hired our first Executive of Diversity, Equity and Inclusion



ENVIRONMENTAL

SOCIAL

PRODUCT

SUPPLY CHAIN

GOVERNANCE

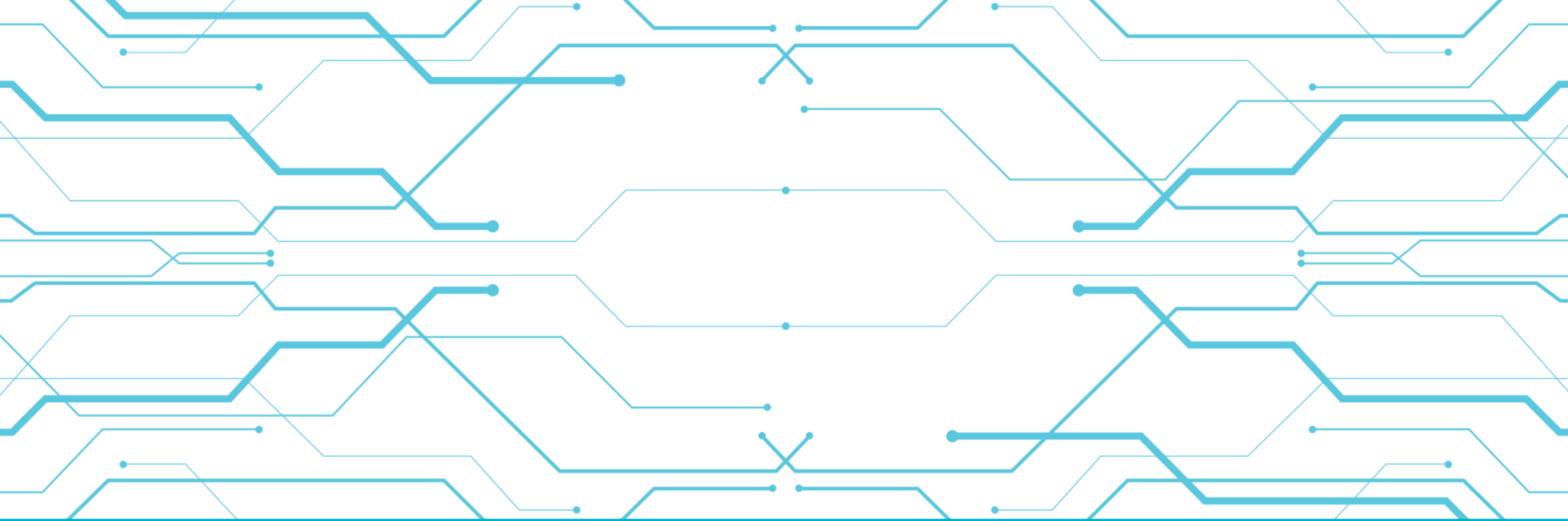

# Electrification Product Technology



BRINGING THE FUTURE  
FASTER

# Growth and Significant CPV Opportunity in EV



BRINGING THE FUTURE  
FASTER

## Outsourced Support

E-Beam Axles and E-Drives

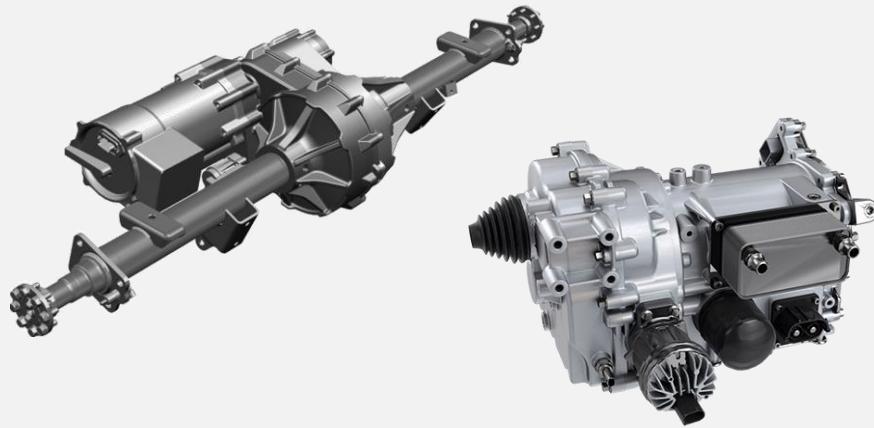

AAM CPV: Up to \$2,500+

## In-House Support

Components

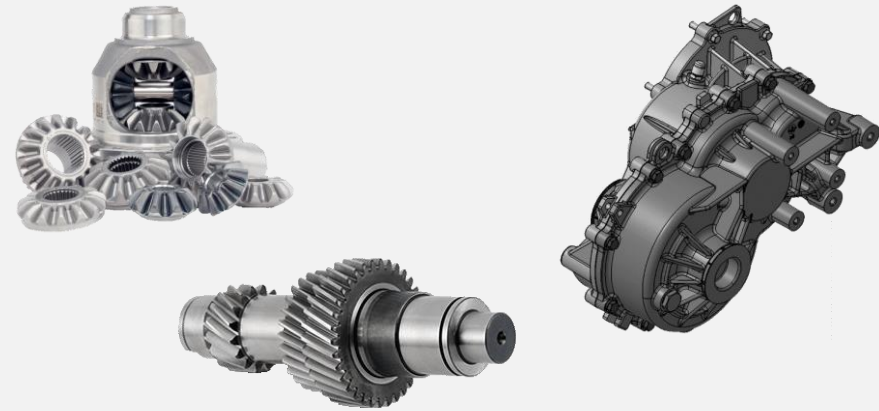

AAM CPV: Up to \$500

**AAM is Positioned to Support All OEM Sourcing Strategies**

# Scalable & Modular Platform



BRINGING THE FUTURE  
FASTER

AAM's Next Generation Scalable & Modular Electric Drive Units support numerous vehicle applications while optimizing capital and development costs

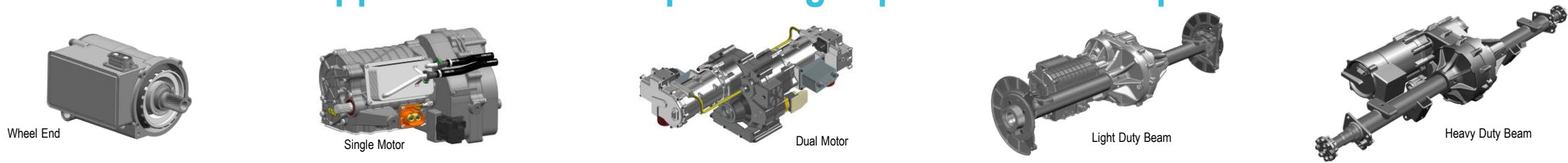

Scalable Power Levels

Modular Motor Construction

Various EDU Architectures

Multiple Gear Ratios

Optional Torque Vectoring & Disconnect

## AAM Traditional Segments



P4 4WD ARCHITECTURE

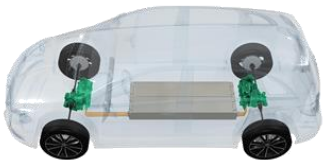

P4 AWD ARCHITECTURE

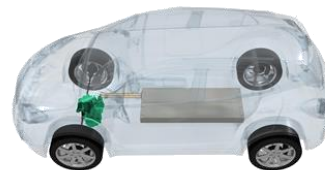

P4 FWD ARCHITECTURE

## New Segment Opportunities



P4 SPLIT AXLE HYBRID ARCHITECTURE

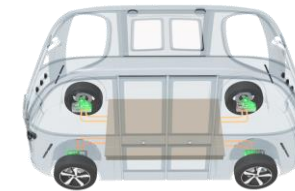

P4 AWD MPV ARCHITECTURE



P4 WHEEL END ARCHITECTURE



P3 HYBRID ARCHITECTURE



P4 RWD ARCHITECTURE

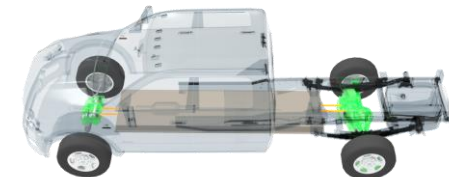

P4 4WD HD ARCHITECTURE

Denotes AAM EDU application.



# Beam Axle vs. E-Beam Axle



BRINGING THE FUTURE  
FASTER

## ICE Beam Axle

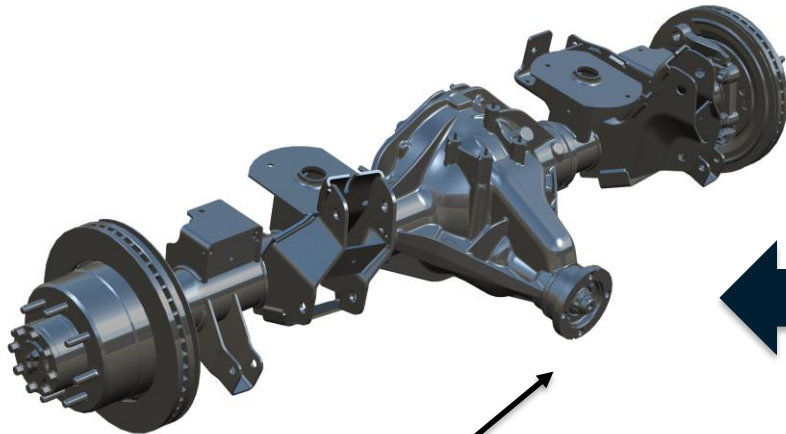

Power comes from internal combustion engine through the driveshaft

### Similarities ICE vs. EV

- Component design and vehicle systems integration
- NVH excellence
- Tubes, structural members and suspension interface
- Differential assembly
- Axle shafts
- Wheel hubs and brakes
- Hypoid gears (ICE) replaced with helical gears (EV)

## E-Beam Axle

Significant CPV Potential

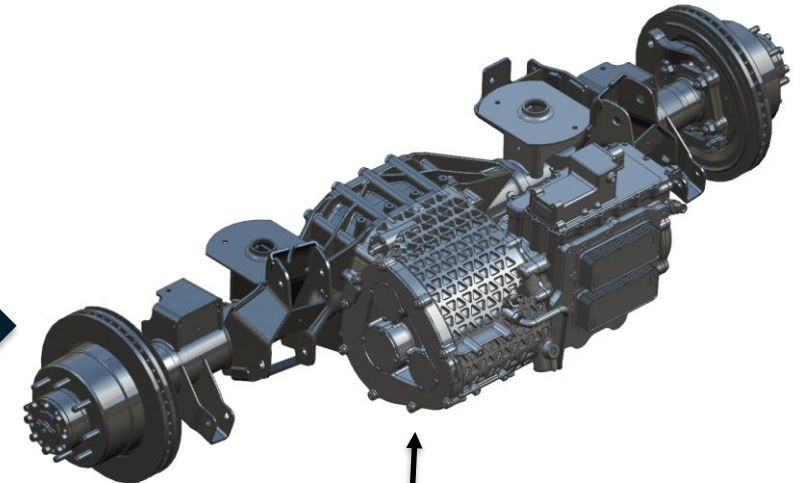

eDU (motor, inverter, gearbox) is integrated into the beam axle; electric power comes from battery  
Additional content includes park lock, software and controls, and multi-speed gearboxes with shift systems

Competitive Advantage and Deep Understanding in Beam Axles Well Position AAM for the e-Beam Segment

# AAM Key Electrification Awards



BRINGING THE FUTURE  
FASTER

## Electric Beam Axles

### Stellantis Electric Vehicle Program

- Front and Rear e-Beam Axles
- 3-in-1 configuration

### Jupiter Electric Mobility

- 2-in-1 configuration

### Pinnacle Mobility EKA

- 3-in-1 configuration

Note: depicted e-Beam axles are for illustrative purposes only

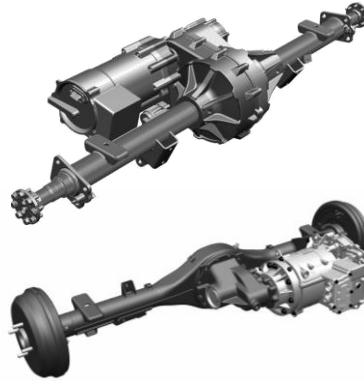

Latter  
Part of the  
Decade  
Launch

Mid-  
Decade  
Launch

## 2-in-1 Electric Drive Units

### AMG High-Performance Luxury (Europe)

- P3 Hybrid Electric Drive Unit
- 160kW Peak Power
- 2-speed Concentric Gearbox Design
- Integrated TracRite® eLSD



Launched

### Jaguar I-PACE (Europe)

- Two P4 Electric Drive Units
- 147 kW Power Level
- Power Dense Concentric Design
- Integrated Park Lock (Front EDU only)



Launched

## 3-in-1 Electric Drive Units (Platform)

### AAM Next Generation 3-in-1 eDrive

- P4 Platform Wheel End Electric Drive Units
- 4x 100kW Units per Vehicle
- Compact Offset Gearbox Design
- Integrated SiC MOSFET Inverter



Mid-decade  
Launch

### AAM / Inovance 3-in-1 eDrive (China)

- P4 Platform Electric Drive Units
- Scalable Power Levels (100-145kW)
- Offset Gearbox Design
- Optional Park Lock

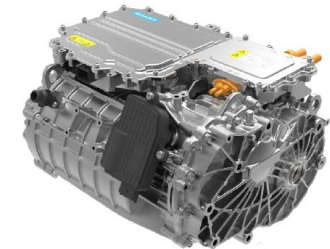

Multiple  
Programs  
Awarded &  
Launched

## Electric Drive Components

### Electric Drive Unit Differentials

- Multiple Chinese BEV Car & SUV Awards
- Multiple North American Light Vehicle Awards
- North American BEV Semi-Truck Application



Multiple  
Programs  
Awarded  
and  
Launched

### Planetary Geartrain

- Supply Volvo Cars with electric drive gears



Awarded 20+ Different Electrification Vehicle Programs

# AAM's Addressable Electric Vehicle Market



BRINGING THE FUTURE  
FASTER

AAM anticipates the addressable sourcing market at  
**\$20-\$30 billion by 2030\***

- This includes full systems, subsystems and components
- We offer solutions for various OEM go-to-market strategies for electric vehicles
- Our technology is a key differentiator
- AAM expects to achieve a strong position in the global electric-beam axle segment
- We expect the market to grow past 2030

## Addressable Market Opportunity

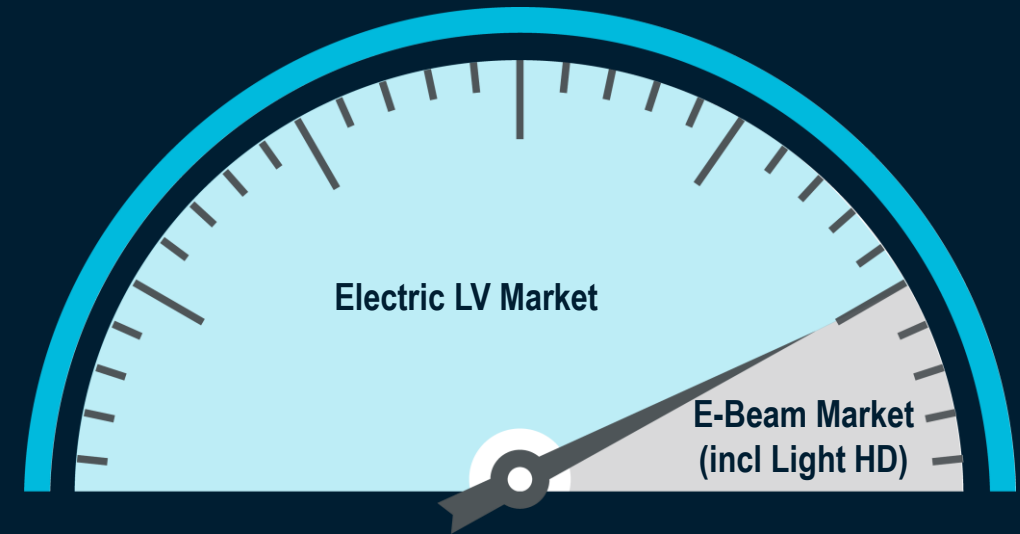



# 2030 Electrification Market Share Goal



BRINGING THE FUTURE  
**FASTER**

## Target >10% Share Of Our Estimated Addressable Market By 2030

Combined with a strong foundational ICE business, AAM revenues have opportunity to grow through 2030

Heritage of quality, technology leadership and operational excellence.

Broad geographical footprint supports market share growth in Asia and Europe while maintaining strong NA position.

Similar outsourcing dynamics between our legacy and electrification business. Legacy market share > 10%.

Robust innovative product platform serving multiple vehicle segments.

Broad portfolio in electric drives (including e-beam axles) and components allow for full participation in OEM sourcing strategies.

Higher outsourcing probability and share opportunity for e-beam axles.

# AAM Long-Term Value Creation



BRINGING THE FUTURE  
FASTER



## Diversification

- Balanced mix of customers and geography.
- Expand our product portfolio, driving opportunities with new OEMs and regions.
- Agnostic to propulsion market changes.



## Sales

- Grow above market by leveraging scale and technology.
- Electrification will further drive expansion into new segments.
- Protect and extend the core business.
- Offer a compelling value proposition to customers.



## Financials

- Leverage AAM's Operating Systems to drive top tier EBITDA margin and cash flow generation.
- Enhance balance sheet strength.



## Long-Term Focus

- Leader in electric propulsion technology.
- Increase size and scale through organic and inorganic growth.
- Effective deployment of capital.

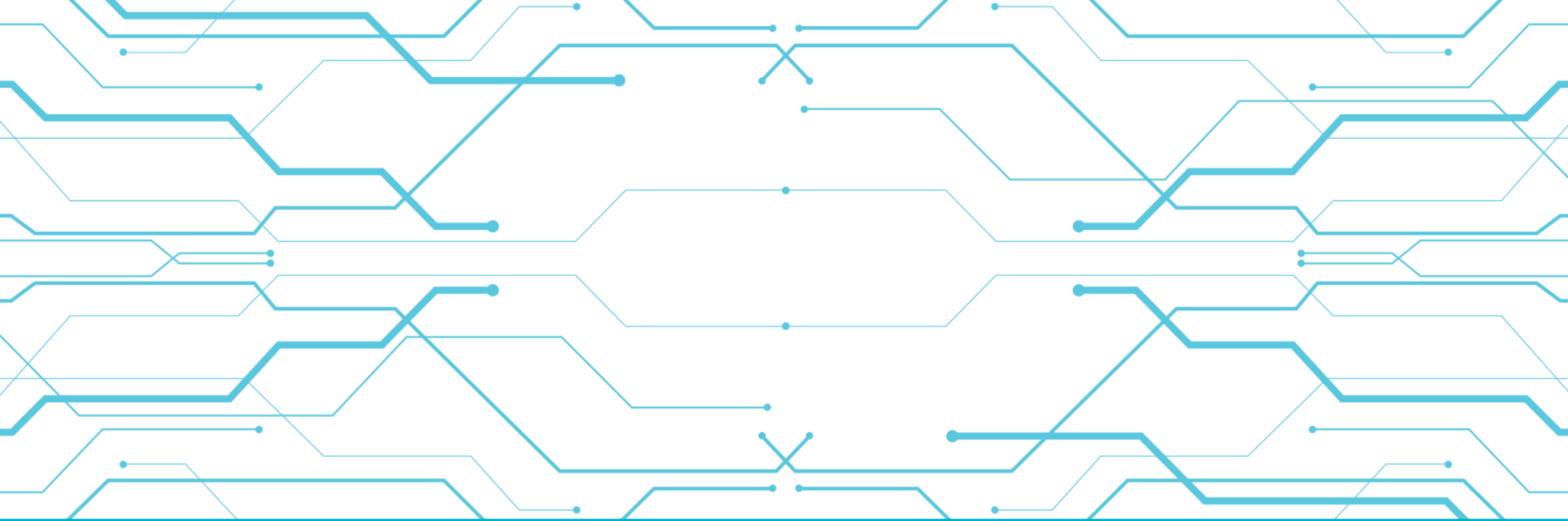

# Supplemental Data



BRINGING THE FUTURE  
FASTER

# Reconciliation of Non-GAAP Measures



BRINGING THE FUTURE  
FASTER

In addition to the results reported in accordance with accounting principles generally accepted in the United States of America (GAAP) included within this presentation, we have provided certain information, which includes non-GAAP financial measures. Such information is reconciled to its closest GAAP measure in accordance with Securities and Exchange Commission rules and is included in the following slides.

Certain of the forward-looking financial measures included in this earnings release are provided on a non-GAAP basis. A reconciliation of non-GAAP forward-looking financial measures to the most directly comparable forward-looking financial measures calculated and presented in accordance with GAAP has been provided. The amounts in these reconciliations are based on our current estimates and actual results may differ materially from these forward-looking estimates for many reasons, including potential event driven transactional and other non-core operating items and their related effects in any future period, the magnitude of which may be significant.



## EBITDA and Adjusted EBITDA Reconciliation (\$ in millions)

|   | Three Months Ended |          |
|---|--------------------|----------|
|   | March 31,          |          |
|   | 2023               | 2022     |
| Net income (loss)                                 | \$ (5.1)           | \$ 1.0   |
| Interest expense                                  | 50.5               | 44.7     |
| Income tax expense                                | -                  | 3.0      |
| Depreciation and amortization                     | 124.9              | 120.4    |
| EBITDA  | 170.3              | 169.1    |
| Restructuring and acquisition-related costs       | 4.8                | 8.9      |
| Debt refinancing and redemption costs             | -                  | 5.6      |
| Unrealized loss on equity securities              | 0.3                | 18.0     |
| Non-recurring items:                              |                    |          |
| Malvern fire insurance recoveries, net of charges | -                  | (5.5)    |
| Adjusted EBITDA                                   | \$ 175.4           | \$ 196.1 |
| Sales   | 1,493.9            | 1,436.2  |
| as a % of net sales                               | 11.7%              | 13.7%    |

\*Please refer to definition of Non-GAAP measures.

# Supplemental Data



BRINGING THE FUTURE  
FASTER

## EBITDA and Adjusted EBITDA for the Trailing Twelve Months Ended March 31, 2023 (\$ in millions)

|   | Quarter Ended    |                       |                      |                   | Trailing Twelve Months Ended |
|---|------------------|-----------------------|----------------------|-------------------|------------------------------|
|   | June 30,<br>2022 | September 30,<br>2022 | December 31,<br>2022 | March 31,<br>2023 | March 31,<br>2023            |
| Net income (loss)                                   | \$ 22.9          | \$ 26.5               | \$ 13.9              | \$ (5.1)          | \$ 58.2                      |
| Interest expense                                    | 42.7             | 44.8                  | 42.3                 | 50.5              | 180.3                        |
| Income tax expense (benefit)                        | 0.6              | (5.7)                 | 4.1                  | -                 | (1.0)                        |
| Depreciation and amortization                       | 121.9            | 124.8                 | 125.0                | 124.9             | 496.6                        |
| EBITDA  | 188.1            | 190.4                 | 185.3                | 170.3             | 734.1                        |
| Restructuring and acquisition-related costs         | 9.6              | 7.9                   | 3.8                  | 4.8               | 26.1                         |
| Debt refinancing and redemption costs               | 0.2              | 0.2                   | 0.4                  | -                 | 0.8                          |
| Unrealized loss on equity securities                | 3.7              | 2.3                   | 1.5                  | 0.3               | 7.8                          |
| Non-recurring items:                                |                  |                       |                      |                   |                              |
| Malvern fire insurance recoveries, net of charges   | 0.1              | (1.0)                 | (32.7)               | -                 | (33.6)                       |
| Acquisition-related fair value inventory adjustment | 5.0              | -                     | -                    | -                 | 5.0                          |
| Gain on bargain purchase of business                | (11.6)           | (1.4)                 | (0.6)                | -                 | (13.6)                       |
| Adjusted EBITDA                                     | \$ 195.1         | \$ 198.4              | \$ 157.7             | \$ 175.4          | \$ 726.6                     |
| Sales   | 1,438.3          | 1,535.2               | 1,392.7              | 1,493.9           | 5,860.1                      |
| as a % of net sales                                 | 13.6%            | 12.9%                 | 11.3%                | 11.7%             | 12.4%                        |

\*Please refer to definition of Non-GAAP measures.



## Adjusted Earnings (Loss) Per Share Reconciliation

|   | Three Months Ended<br>March 31, |                |
|---|---------------------------------|----------------|
|   | 2023                            | 2022           |
| Diluted earnings (loss) per share                 | \$ (0.04)                       | \$ 0.01        |
| Restructuring and acquisition-related costs       | 0.04                            | 0.07           |
| Debt refinancing and redemption costs             | -                               | 0.05           |
| Unrealized loss on equity securities              | -                               | 0.15           |
| Non-recurring items:                              |                                 |                |
| Malvern fire insurance recoveries, net of charges | -                               | (0.05)         |
| Tax effect of adjustments                         | (0.01)                          | (0.04)         |
| Adjusted earnings (loss) per share                | <u>\$ (0.01)</u>                | <u>\$ 0.19</u> |

\*Please refer to definition of Non-GAAP measures.



## Free Cash Flow and Adjusted Free Cash Flow Reconciliation (\$ in millions)

|   | Three Months Ended<br>March 31, |         |
|---|---------------------------------|---------|
|   | 2023                            | 2022    |
| Net cash provided by operating activities   | \$ 32.1                         | \$ 68.5 |
| Capital expenditures net of proceeds from the sale of property, plant and equipment | (46.2)                          | (24.4)  |
| Free cash flow  | (14.1)                          | 44.1    |
| Cash payments for restructuring and acquisition-related costs                       | 4.0                             | 8.4     |
| Cash payments (insurance proceeds) related to Malvern fire, net                     | (7.0)                           | 1.4     |
| Adjusted free cash flow   | \$ (17.1)                       | \$ 53.9 |

\*Please refer to definition of Non-GAAP measures.





## Net Debt and Net Leverage Ratio (\$ in millions)

|                                   | <b>March 31,<br/>2023</b> |
|-----------------------------------|---------------------------|
| Current portion of long term debt | \$ 49.6                   |
| Long-term debt, net               | <u>2,847.7</u>            |
| Total debt, net                   | 2,897.3                   |
| Less: Cash and cash equivalents   | <u>465.7</u>              |
| Net debt at end of period         | <u>2,431.6</u>            |
| Adjusted LTM EBITDA               | <u>\$ 726.6</u>           |
| <br>Net Leverage Ratio            | <br>3.3x                  |



**Segment Financial Information**  
(\$ in millions)

|                               | Three Months Ended |                   |
|-------------------------------|--------------------|-------------------|
|                               | March 31,          |                   |
|                               | 2023               | 2022              |
| Segment Sales                 |                    |                   |
| Driveline                     | \$ 1,013.8         | \$ 1,045.4        |
| Metal Forming                 | 619.1              | 525.1             |
| Total Sales                   | 1,632.9            | 1,570.5           |
| Intersegment Sales            | (139.0)            | (134.3)           |
| Net External Sales            | <u>\$ 1,493.9</u>  | <u>\$ 1,436.2</u> |
| Segment Adjusted EBITDA       |                    |                   |
| Driveline                     | \$ 114.1           | \$ 122.8          |
| Metal Forming                 | 61.3               | 73.3              |
| Total Segment Adjusted EBITDA | <u>\$ 175.4</u>    | <u>\$ 196.1</u>   |

\*Please refer to definition of Non-GAAP measures.

# Supplemental Data



BRINGING THE FUTURE  
FASTER

®

|   | Adjusted EBITDA      |               |
|---|----------------------|---------------|
|   | Low End              | High End      |
|   | <i>(in millions)</i> |               |
| Net income                                  | \$ 5                 | \$ 35         |
| Interest expense                            | 200                  | 200           |
| Income tax expense                          | 5                    | 50            |
| Depreciation and amortization               | 490                  | 490           |
| Full year 2023 targeted EBITDA              | 700                  | 775           |
| Restructuring and acquisition-related costs | 25                   | 25            |
| Full year 2023 targeted Adjusted EBITDA     | <u>\$ 725</u>        | <u>\$ 800</u> |

|   |               |               |
|---|---------------|---------------|
| Net cash provided by operating activities   | \$ 435        | \$ 510        |
| Capital expenditures net of proceeds from the sale of property, plant and equipment | (230)         | (230)         |
| Full year 2023 targeted Free Cash Flow  | 205           | 280           |
| Cash payments for restructuring and acquisition-related costs                       | 25            | 25            |
| Other   | (5)           | (5)           |
| Full year 2023 targeted Adjusted Free Cash Flow                                     | <u>\$ 225</u> | <u>\$ 300</u> |

|   | Adjusted Free Cash Flow |               |
|---|-------------------------|---------------|
|   | Low End                 | High End      |
|   | <i>(in millions)</i>    |               |
| Net cash provided by operating activities   | \$ 435                  | \$ 510        |
| Capital expenditures net of proceeds from the sale of property, plant and equipment | (230)                   | (230)         |
| Full year 2023 targeted Free Cash Flow  | 205                     | 280           |
| Cash payments for restructuring and acquisition-related costs                       | 25                      | 25            |
| Other   | (5)                     | (5)           |
| Full year 2023 targeted Adjusted Free Cash Flow                                     | <u>\$ 225</u>           | <u>\$ 300</u> |

# Definition of Non-GAAP Measures



BRINGING THE FUTURE  
FASTER

## **EBITDA and Adjusted EBITDA**

We define EBITDA to be earnings before interest expense, income taxes, depreciation and amortization. Adjusted EBITDA is defined as EBITDA excluding the impact of restructuring and acquisition-related costs, debt refinancing and redemption costs, loss on sale of business, pension settlements, unrealized gains or losses on equity securities and non-recurring items. Our management, the investment community and the banking institutions routinely use EBITDA and Adjusted EBITDA, together with other measures, to measure our operating performance relative to other Tier 1 automotive suppliers. We also use Segment Adjusted EBITDA as the measure of earnings to assess the performance of each segment and determine the resources to be allocated to the segments. EBITDA and Adjusted EBITDA are also key metrics used in our calculation of incentive compensation. EBITDA and Adjusted EBITDA should not be construed as income from operations, net income or cash flow from operating activities as determined under GAAP. Other companies may calculate EBITDA and Adjusted EBITDA differently.

## **Adjusted Earnings (Loss) Per Share**

We define Adjusted earnings (loss) per share to be diluted earnings (loss) per share excluding the impact of restructuring and acquisition-related costs, debt refinancing and redemption costs, loss on sale of business, pension settlements, unrealized gains or losses on equity securities and non-recurring items, including the tax effect thereon. We believe Adjusted earnings per share is a meaningful measure as it is commonly utilized by management and investors in assessing ongoing financial performance that provides improved comparability between periods through the exclusion of certain items that management believes are not indicative of core operating performance and which may obscure underlying business results and trends. Other companies may calculate Adjusted earnings per share differently.

## **Free Cash Flow and Adjusted Free Cash Flow**

We define free cash flow to be net cash provided by operating activities less capital expenditures net of proceeds from the sale of property, plant and equipment. Adjusted free cash flow is defined as free cash flow excluding the impact of cash payments for restructuring and acquisition-related costs, and cash payments related to the Malvern fire, including payments for capital expenditures, net of recoveries. We believe free cash flow and Adjusted free cash flow are meaningful measures as they are commonly utilized by management and investors to assess our ability to generate cash flow from business operations to repay debt and return capital to our stockholders. Free cash flow and Adjusted free cash flow are also key metrics used in our calculation of incentive compensation. Other companies may calculate free cash flow and Adjusted free cash flow differently.

## **Net Debt and Net Leverage Ratio**

We define net debt to be total debt, net less cash and cash equivalents. We define Net Leverage Ratio to be net debt divided by the trailing 12 months of Adjusted EBITDA. We believe that Net Leverage Ratio is a meaningful measure of financial condition as it is commonly used by management, investors and creditors to assess capital structure risk. Other companies may calculate Net Leverage Ratio differently.

## **Liquidity**

We define Liquidity as cash on hand plus amounts available on our revolving credit facility and foreign credit facilities.

## **US SAAR**

We define US SAAR as the seasonally adjusted annual rate of light vehicle sales in the United States.

